

SECTION **FL**
FUEL SYSTEM

A
FL
C
D
E
F
G
H
I
J
K
L
M
N
O
P

CONTENTS

SERVICE INFORMATION	2	Removal and Installation	4
PREPARATION	2	Component	8
Commercial Service Tool	2	Disassembly and Assembly	8
FUEL SYSTEM	3	FUEL TANK	10
Checking Fuel Line	3	Component	10
General Precaution	3	Removal and Installation	10
FUEL LEVEL SENSOR UNIT, FUEL FILTER AND FUEL PUMP ASSEMBLY	4	SERVICE DATA AND SPECIFICATIONS (SDS)	13
Component	4	Standard and Limit	13

PREPARATION

< SERVICE INFORMATION >

SERVICE INFORMATION

PREPARATION

Commercial Service Tool

INFOID:000000002955351

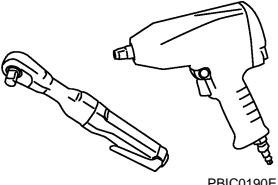
Tool name	Description
<p data-bbox="164 415 272 441">Power tool</p>  <p data-bbox="829 632 901 646">PBIC0190E</p>	<p data-bbox="1013 415 1263 441">Loosening nuts and bolts</p>

FUEL SYSTEM

< SERVICE INFORMATION >

FUEL SYSTEM

Checking Fuel Line

INFOID:000000002955352

Inspect fuel lines, fuel filler cap and fuel tank for improper attachment, leaks, cracks, damage, loose connections, chafing or deterioration.

If necessary, repair or replace damaged parts.

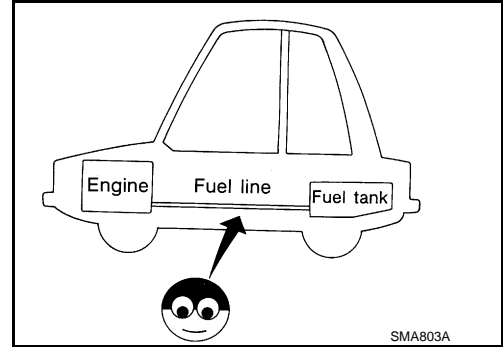

General Precaution

INFOID:000000002955353

WARNING:

When replacing fuel line parts, be sure to observe the following.

- Put a "CAUTION: FLAMMABLE" sign in the workshop.
- Be sure to work in a well ventilated area and furnish workshop with a CO₂ fire extinguisher.
- Never smoke while servicing fuel system. Keep open flames and sparks away from the work area.

CAUTION:

- Use gasoline required by the regulations for octane number. Refer to [GI-5, "Precaution for Fuel \(Unleaded Premium Gasoline Required\) \(VK45DE Engine Models\)"](#).
- Before removing fuel line parts, perform out the following procedures:
 - Put drained fuel in an explosion-proof container and put the lid on securely. Keep the container in safe area.
 - Release fuel pressure from the fuel lines. Refer to [EC-84, "Fuel Pressure Check" \(VQ35DE\)](#) or [EC-708, "Fuel Pressure Check" \(VK45DE\)](#).
 - Disconnect the battery cable from the negative terminal.
 - Always replace O-ring and clamps with new ones.
 - Never kink or twist tubes when they are being installed.
 - Never tighten hose clamps excessively to avoid damaging hoses.
 - After connecting fuel tube quick connectors, check quick connectors are secure. Ensure that connector and resin tube never contact any adjacent parts.
 - After installing tubes, check there is no fuel leakage at connections in the following steps.
 - Apply fuel pressure to fuel lines with turning ignition switch "ON" (with engine stopped). Then check for fuel leaks at connections.
 - Start engine and rev it up and check for fuel leaks at connections.
- Use only a genuine NISSAN fuel filler cap as a replacement. If an incorrect fuel filler cap is used, the "MIL" may come on.
- For servicing "Evaporative Emission System" parts, refer to [EC-40 \(VQ35DE\)](#) or [EC-662 \(VK45DE\)](#).
- For servicing "On Board Refueling Vapor Recovery (ORVR)" parts, refer to [EC-46 \(VQ35DE\)](#) or [EC-668 \(VK45DE\)](#).

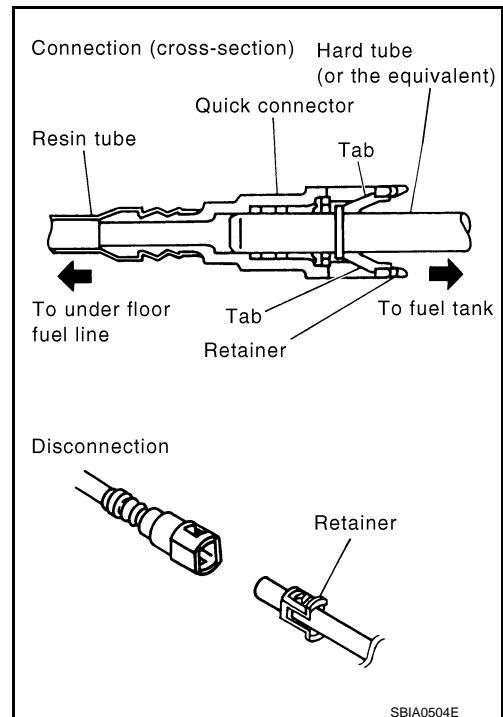

FUEL LEVEL SENSOR UNIT, FUEL FILTER AND FUEL PUMP ASSEMBLY

< SERVICE INFORMATION >

FUEL LEVEL SENSOR UNIT, FUEL FILTER AND FUEL PUMP ASSEMBLY

Component

INFOID:000000002955354

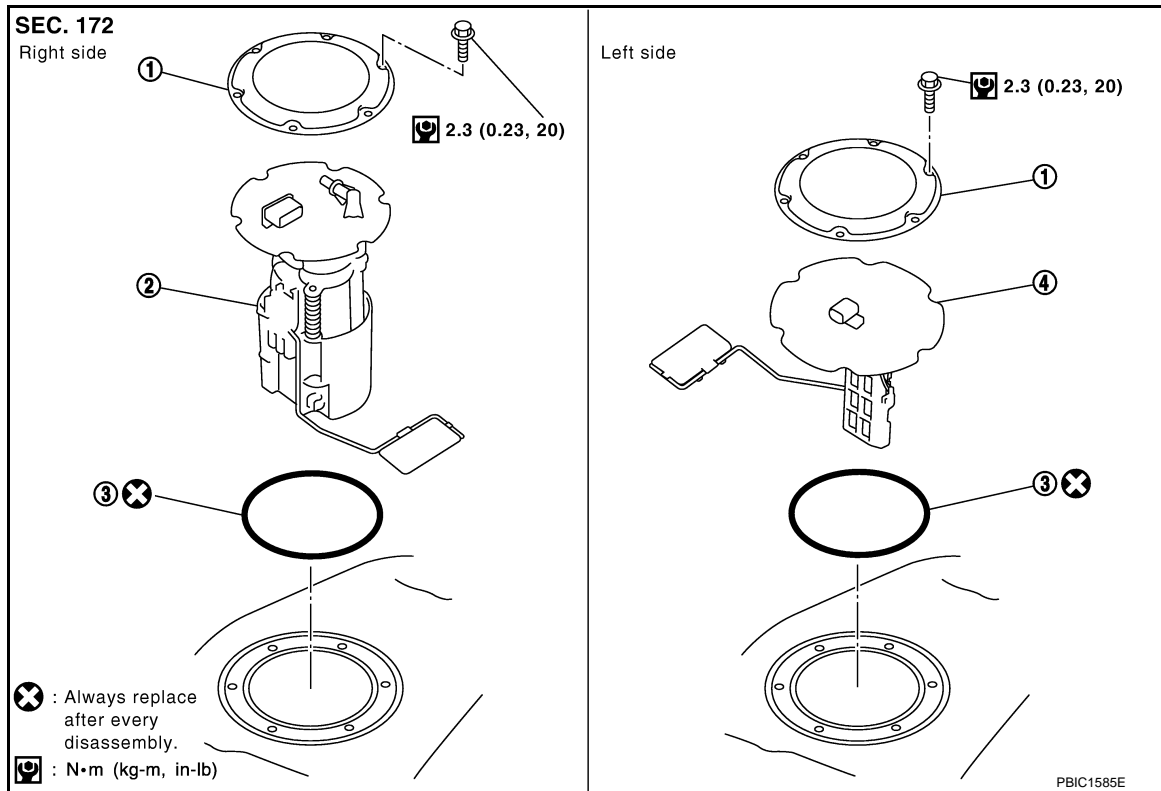

1. Retainer
2. Main fuel level sensor unit, fuel filter and fuel pump assembly
3. O-ring
4. Sub fuel level sensor unit

Removal and Installation

INFOID:000000002955355

REMOVAL

WARNING:

Read “General Precautions” when working on the fuel system. Refer to [FL-3, "General Precaution"](#).

1. Check fuel level on fuel gauge. If fuel gauge indicates more than the level as shown in the figure (full or almost full), drain fuel from fuel tank until fuel gauge indicates level as shown in the figure or below.

NOTE:

Because fuel will be spilled when removing main and sub fuel level sensor units for the top of the fuel is above the main and sub fuel level sensor units installation surface.

- As a guide, fuel level becomes the position as shown in the figure or below when approximately 20 ℓ (5-1/4 US gal, 4-3/8 Imp gal) of fuel are drained from fuel tank.
- In a case that fuel pump does not operate, perform the following procedure.

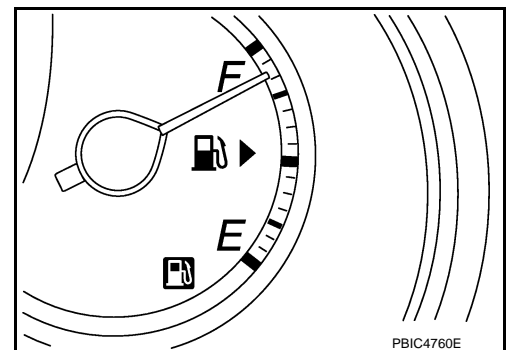

- a. Insert hose of less than 25 mm (0.98 in) in diameter into fuel filler tube through fuel filler opening to draw fuel from fuel filler tube.
- b. Disconnect fuel filler hose from fuel filler tube. Refer to [FL-10](#).
- c. Insert fuel tube into fuel tank through fuel filler hose to draw fuel from fuel tank.

FUEL LEVEL SENSOR UNIT, FUEL FILTER AND FUEL PUMP ASSEMBLY

< SERVICE INFORMATION >

2. Release the fuel pressure from the fuel lines. Refer to [EC-84. "Fuel Pressure Check"](#) (VQ35DE) or [EC-708. "Fuel Pressure Check"](#) (VK45DE).
3. Open fuel filler lid.
4. Open filler cap and release the pressure inside fuel tank.
5. Remove rear seat cushion. Refer to [SE-152](#).
6. Peel off floor carpet, then remove inspection hole cover units by turning clips clockwise by 90 degrees.

Right side : Main fuel level sensor unit, fuel filter and fuel pump assembly

Left side : Sub fuel level sensor unit

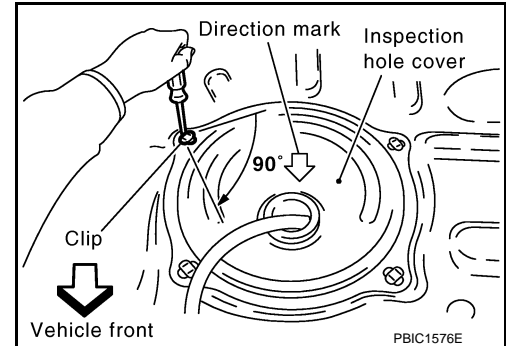

7. Disconnect harness connector and fuel feed tube.

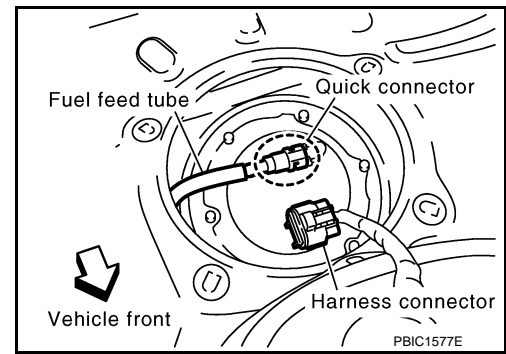

Disconnect quick connector as follows:

- Hold the sides of connector, push in tabs and pull out fuel feed tube.
- If quick connector sticks to tube of main fuel level sensor unit, push and pull quick connector several times until they start to move. Then disconnect them by pulling.

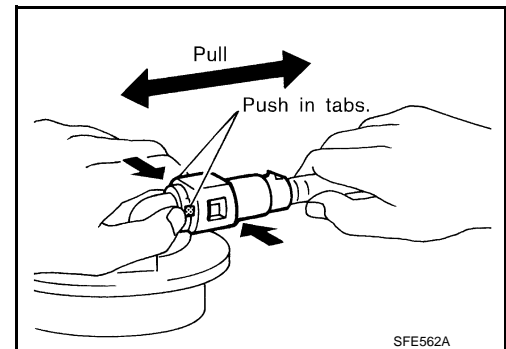

CAUTION:

FUEL LEVEL SENSOR UNIT, FUEL FILTER AND FUEL PUMP ASSEMBLY

< SERVICE INFORMATION >

- Quick connector can be disconnected when the tabs are completely depressed. Never twist it more than necessary.
- Never use any tools to disconnected quick connector.
- Keep resin tube away from heat. Be especially careful when welding near the resin tube.
- Prevent acid liquid such as battery electrolyte, etc. from getting on resin tube.
- Never bend or twist resin tube during installation and disconnection.
- Never remove the remaining retainer on hard tube (or the equivalent) except when resin tube or retainer is replaced.
- When resin tube or hard tube (or the equivalent) is replaced, also replace retainer with new one.

Retainer color: Green

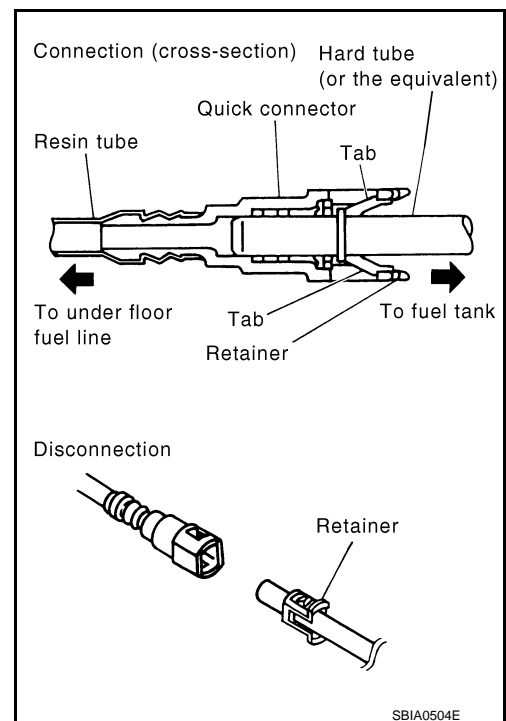

- To keep the connecting portion clean and to avoid damage and foreign materials, cover them completely with plastic bags or something similar.

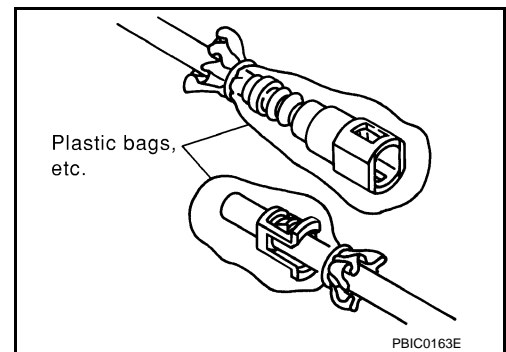

8. Remove main fuel level sensor unit, fuel filter and fuel pump assembly, and sub fuel level sensor unit as follows:

CAUTION:

- Never bend float arm during removal.
- Avoid impacts such as falling when handling components.

- a. Removal of main fuel level sensor unit, fuel filter and fuel pump assembly:

- Remove retainer.
- Raise main fuel level sensor unit, fuel filter and fuel pump assembly, and using snap ring pliers, remove fuel hose connector.

CAUTION:

Be careful not to damage fuel hose connector by expanding them excessively.

- b. Removal of sub fuel level sensor unit:

- Remove retainer.
- Raise and release sub fuel level sensor unit to remove.

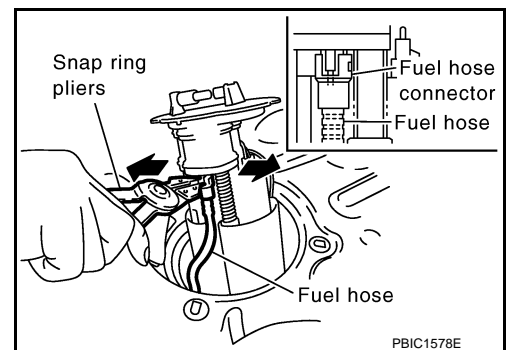

INSTALLATION

Note to the following, and install in the reverse order of removal.

Fuel hose

FUEL LEVEL SENSOR UNIT, FUEL FILTER AND FUEL PUMP ASSEMBLY

< SERVICE INFORMATION >

- When installing fuel hose connector insert them fully until a click sound of full stopper engagement is heard.

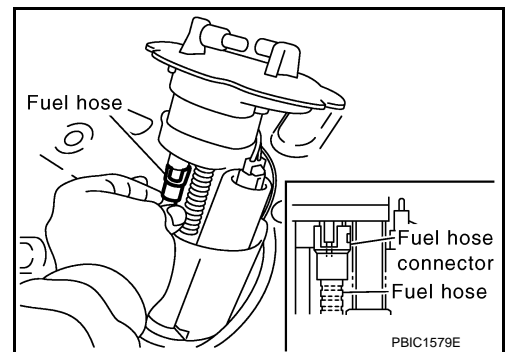

Main and Sub Fuel Level Sensor Unit

- Face main and sub fuel level sensor units as shown in the figure, and install them with the knock pin on back aligned with pin hole on fuel tank.

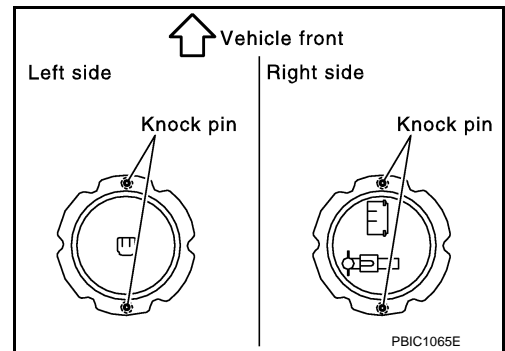

- Install retainer so that its notch becomes parallel with the notch on fuel tank.
- Tighten retainer mounting bolts evenly.

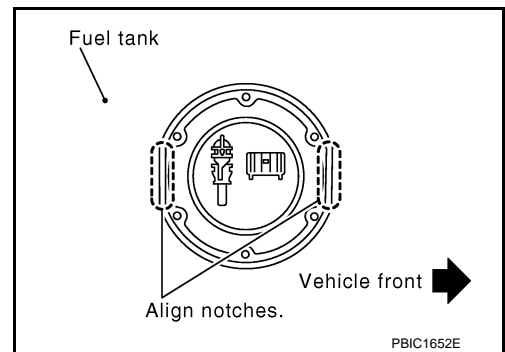

Quick Connector

Connect quick connector as follows:

1. Check the connection for damage or any foreign materials.
2. Align the connector with the tube, then insert the connector straight into the tube until a click sound is heard.
3. After connecting, check that the connection is secure by following method.
 - Pull the tube and the connector to check they are securely connected.
 - Visually confirm that the two retainer tabs are connected to the connector.

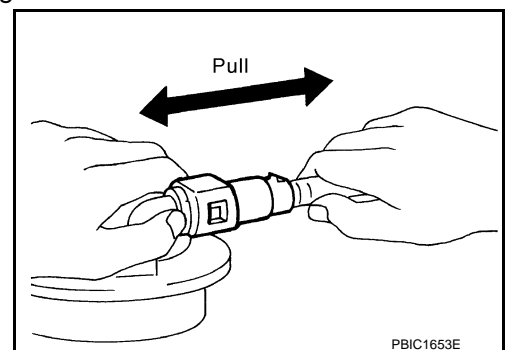

INSPECTION AFTER INSTALLATION

Use the following procedure to check for fuel leaks.

FUEL LEVEL SENSOR UNIT, FUEL FILTER AND FUEL PUMP ASSEMBLY

< SERVICE INFORMATION >

1. Turn ignition switch "ON" (with engine stopped), then check connections for leaks by applying fuel pressure to fuel piping.
2. Start engine and let it idle and check there are no fuel leaks at the fuel system connections.

Component

INFOID:000000002955356

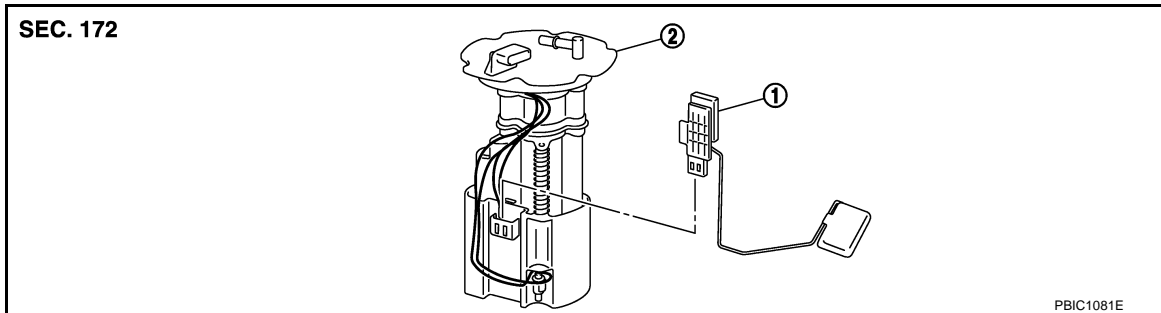

1. Fuel level sensor unit
2. Fuel filter and fuel pump assembly

Disassembly and Assembly

INFOID:000000002955357

CAUTION:

Sub fuel level sensor unit cannot be disassembled and should be replaced as a unit.

DISASSEMBLY

Remove fuel level sensor unit as follows.

1. Disconnect harness connector.
 - Hold connector by fingers and pull it out, because there is no stopper release tab.

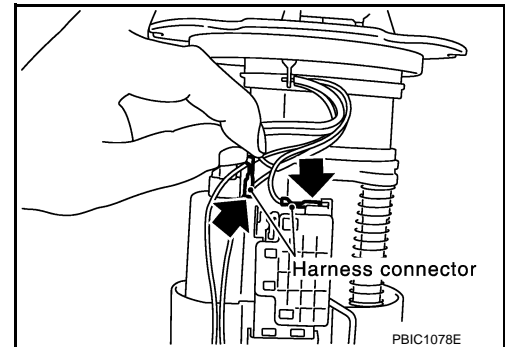

2. Using suitable tool, pull up tabs points as shown in the figure (two points) to release the lock.

CAUTION:

Be careful not to damage it.

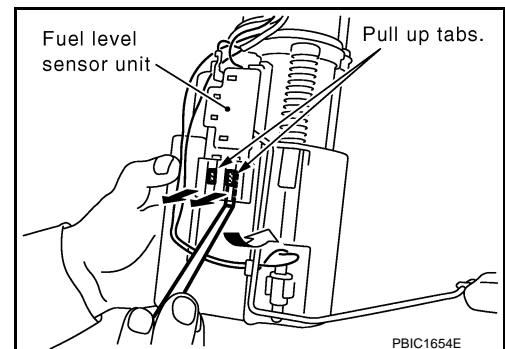

FUEL LEVEL SENSOR UNIT, FUEL FILTER AND FUEL PUMP ASSEMBLY

< SERVICE INFORMATION >

3. After fixing tabs are disengaged, slide fuel level sensor unit out in direction shown by the arrow.

CAUTION:

Never disassemble fuel filter and fuel pump assembly.

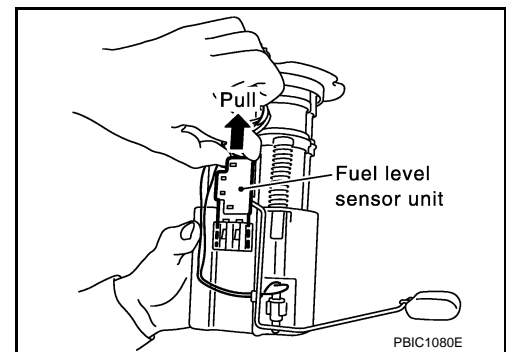

ASSEMBLY

1. Check for damage of fuel level sensor unit installation position on the side of fuel filter and fuel pump assembly.
2. Slide fuel level sensor unit until it aligns to installation groove, then insert it until it stops.
 - After inserting, apply force in reverse direction (removal direction) to ensure it cannot be pulled out.
3. Connect the black (A) and white (B) harnesses so that they are in the positions shown in the figure.
 - Securely insert harness connector until it stops.

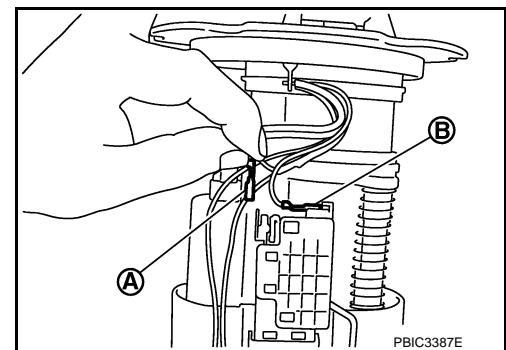

A

FL

C

D

E

F

G

H

I

J

K

L

M

N

O

P

FUEL TANK

< SERVICE INFORMATION >

FUEL TANK

Component

INFOID:000000002955358

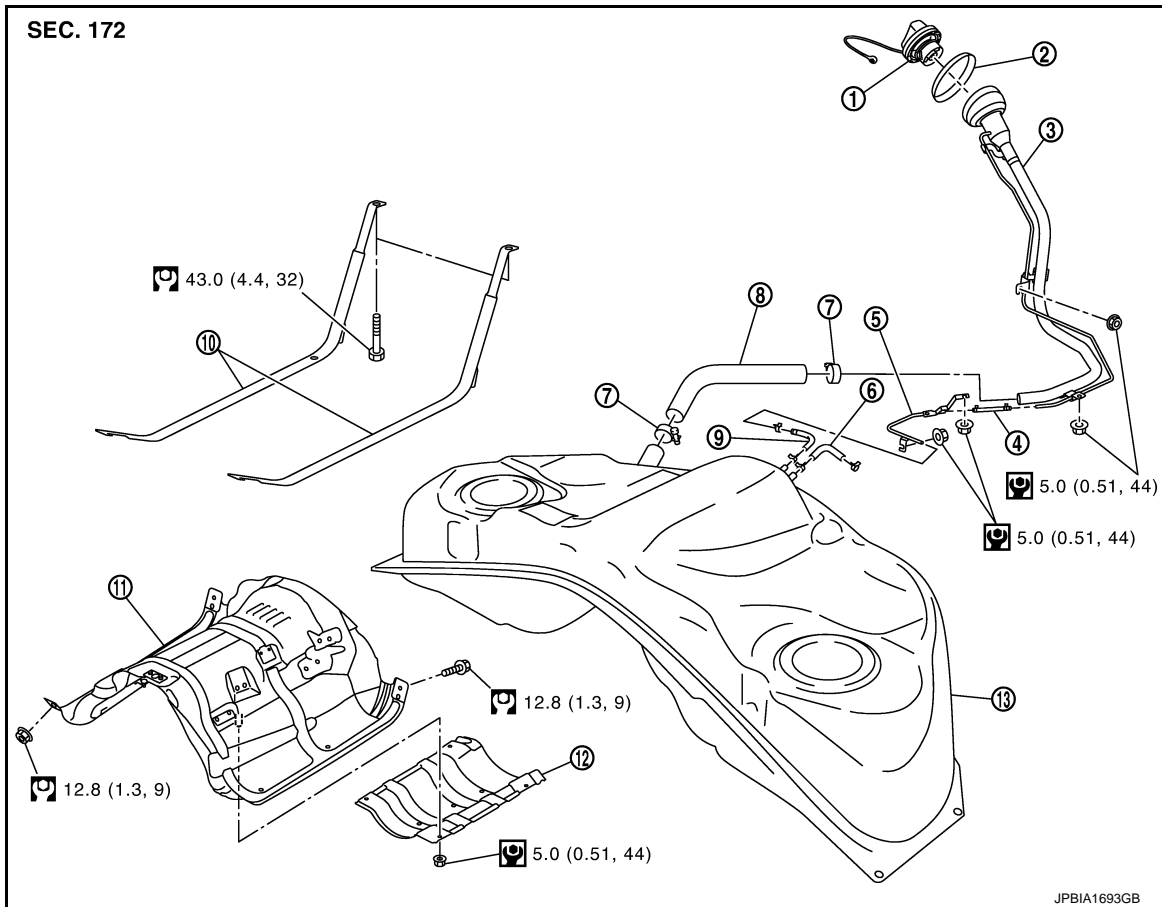

- | | | |
|-----------------------------|-------------------------|---------------------|
| 1. Fuel filler cap | 2. Grommet | 3. Fuel filler tube |
| 4. Vent hose | 5. Vent tube | 6. EVAP hose |
| 7. Clamp | 8. Fuel filler hose | 9. Vent hose |
| 10. Fuel tank mounting band | 11. Fuel tank protector | 12. Insulator |
| 13. Fuel tank | | |

- Refer to [GI-9. "Component"](#) for symbols in the figure.

Removal and Installation

INFOID:000000002955359

REMOVAL

WARNING:

Be sure to read "General Precautions" when working on the fuel system. Refer to [FL-3. "General Precaution"](#).

- Drain fuel from fuel tank if necessary. Refer to [FL-4. "Removal and Installation"](#).
 - Perform work on level place.
1. Perform steps 2 to 7 of "REMOVAL" in "FUEL LEVEL SENSOR UNIT, FUEL FILTER AND FUEL PUMP ASSEMBLY" on main and sub fuel level sensor units. Refer to [FL-4. "Removal and Installation"](#).
 2. Remove exhaust front tube, center muffler and main muffler. Refer to [EX-3](#).
 3. Remove propeller shaft. Refer to [PR-7](#).
 4. Remove parking rear brake cables. Refer to [PB-4](#).
 5. Remove rear suspension assembly. Refer to [RSU-5](#).
 6. Remove fuel tank protector.

FUEL TANK

< SERVICE INFORMATION >

7. Disconnect fuel filler hose, vent hose and EVAP hoses at fuel tank side.

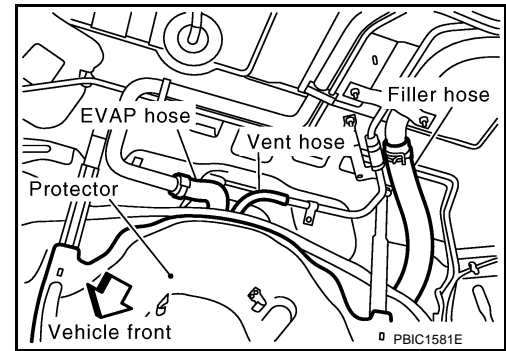

8. Support the lower part of fuel tank with transmission jack.
CAUTION:
Support the position that fuel tank mounting bands never engage.

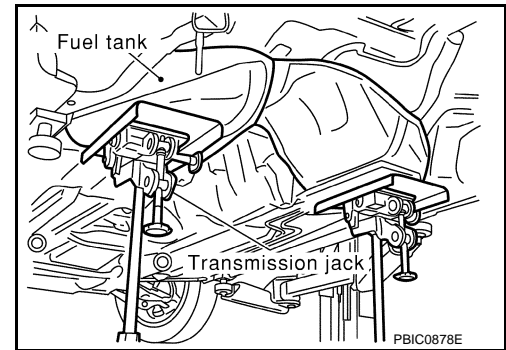

9. Remove fuel tank mounting bands.
10. Supporting with hands, descend transmission jack carefully, and remove fuel tank.
CAUTION:
 - Check that all connection points have been disconnected.
 - Confirm there is no interference with vehicle.
11. Remove fuel filler tube, as necessary.

INSTALLATION

Note the following, and install in the reverse order of removal.

- Surely clamp fuel hoses and insert hose to the length below.

Fuel filler hose : 35 mm (1.38 in)
The other hoses : 25 mm (0.98 in)

- Be sure hose clamp is not placed on swelled area of fuel tube.
- Tighten the clamp hand with the top mark (A) until the mark is on the bolt head flange.

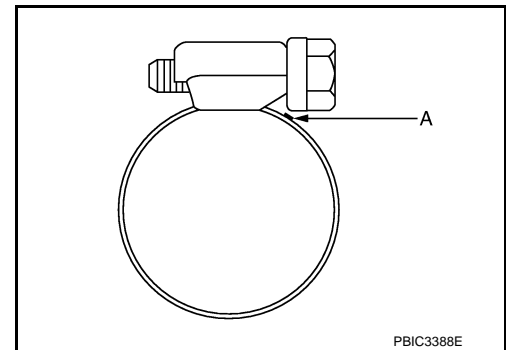

- To connect quick connector, refer to [FL-4, "Removal and Installation"](#).

INSPECTION AFTER INSTALLATION

Use the following procedure to check for fuel leaks.

1. Turn ignition switch "ON" (with engine stopped), and check connections for leakage by applying fuel pressure to fuel piping.

FUEL TANK

< SERVICE INFORMATION >

2. Start engine and rev it up and check there are no fuel leaks at the fuel system tube and hose connections.
- After removing/installing rear suspension assembly, check to adjust wheel alignment and then, adjust neutral position of steering angle sensor. Refer to [RSU-5. "Wheel Alignment Inspection"](#) and [BRC-8. "Adjustment of Steering Angle Sensor Neutral Position"](#).

SERVICE DATA AND SPECIFICATIONS (SDS)

< SERVICE INFORMATION >

SERVICE DATA AND SPECIFICATIONS (SDS)

Standard and Limit

INFOID:000000002955360

FUEL TANK

A

FL

Fuel tank capacity	Approx. 76 ℓ (20-1/8 US gal, 16-3/4 Imp gal)
Fuel recommendation	Refer to GI-5

C

D

E

F

G

H

I

J

K

L

M

N

O

P